

# Discussion: Probability Theory and Fuzzy Logic Are Complementary Rather Than Competitive

Lotfi A. ZADEH

Computer Science Division  
Department of EECS  
University of California  
Berkeley, CA 94720-1776

The relationship between probability theory and fuzzy logic has long been an object of discussion and some controversy. The position articulated in this article is that probability theory by itself is not sufficient for dealing with uncertainty and imprecision in real-world settings. To enhance its effectiveness, probability theory needs an infusion of concepts and techniques drawn from fuzzy logic—especially the concept of a linguistic variable and the calculus of fuzzy if-then rules. In the final analysis, probability theory and fuzzy logic are complementary rather than competitive.

Traditionally, probability theory has been viewed as the methodology of choice for dealing with uncertainty and imprecision. It is this view that has been called into question by the advent of fuzzy set theory or, as it is commonly referred to today, fuzzy logic.

The central point at issue is the sufficiency of probability theory. The core of the position put forth in this article is that probability theory by itself is not sufficient and that it must be used in concert with fuzzy logic to enhance its effectiveness. In this perspective, probability theory and fuzzy logic are complementary rather than competitive.

What are the connections between fuzzy logic and probability theory? Is fuzzy logic subsumed by probability theory or vice versa? Is there anything that can be done with fuzzy logic that cannot be done equally well or better by probability theory? Is fuzzy logic a disguised form of probability theory? What are the shortcomings of probability theory as a methodology for dealing with uncertainty? What can be done with fuzzy logic that cannot be done with probability theory? These are some of the questions that have been discussed at length in the literature (Buoncrisiani 1980; Dubois and Prade 1993; Freeling 1981; Klir 1989; Kosko 1990; Nguyen 1977; Nurmi 1977; Rapoport, Walsten, and Cox 1985; Stallings 1977; Sugeno 1977; Viertl 1987; Yager 1984; Zadeh 1968, 1980, 1981, 1983, 1984, 1988) since the appearance of the first article on fuzzy sets (Zadeh 1965).

The earliest article to consider a connection between fuzzy sets and probabilities was authored by Loginov (1966). In his article, Loginov suggested that the membership function of a fuzzy set may be interpreted as a conditional probability. Similar suggestions were made later by Hisdal (1986), Cheeseman (1986), and many others. In this article, I shall return to Loginov's suggestion at a later point.

In many of the works dealing with the questions just cited, one finds assertions that reflect a lack of familiarity with fuzzy logic or a misunderstanding of what it has to offer. This does not apply to the article by Laviolette, Seaman, Barrett, and Woodall in this issue of *Technometrics*. The authors of the article under discussion offer seasoned arguments and carefully worked out examples. Nevertheless there are many significant issues that are not addressed in their article. These issues affect the validity of their analysis and lead to conclusions that are quite different from those arrived at by the authors.

In what follows, I will argue briefly that (a) probability theory and fuzzy logic are distinct, (b) that probability theory is not sufficient by itself for dealing with uncertainty and imprecision, and (c) that probability theory and fuzzy logic are complementary rather than competitive.

## 1. CONNECTIONS BETWEEN PROBABILITY THEORY AND FUZZY LOGIC

Among the connections and points of tangency between probability theory and fuzzy logic, the principal one is centered on Loginov's suggestion and the closely related viewpoints involving voting and consensus models, random sets, and the plausibility measure of the Dempster-Shafer theory. These connections do not imply that fuzzy logic is subsumed by probability theory or vice versa. In fact, probability theory and fuzzy logic have distinct agendas and different domains of applicability.

Let us start with Loginov's suggestion, which is closely related to the approach used in the article under discussion.

Consider a fuzzy set  $A$  in a universe of discourse  $U$ —for example, the fuzzy set *young* in the interval  $U = [0, 100]$ .  $A$  is characterized by its membership function  $\mu_A: U \rightarrow [0, 1]$ , with  $\mu_A(u)$  representing the grade of

membership of  $u$  in  $A$ . For example, in the case of *young*, we may have  $\mu_{young}(25) = .8$ . It is understood that  $\mu_A$  is context-dependent.

Let  $X$  be a random variable that can take the values  $A$  and  $A'$  (not  $A$ ), with  $A$  and  $A'$  interpreted as symbols. In essence, Loginov's suggestion is to interpret  $\mu_A(u)$  as the conditional probability,  $\Pr(A|u)$ , that  $X = A$  for a given  $u$ . More concretely, assume that we have a collection of voters  $V = \{V_1, \dots, V_N\}$ , with each  $V_i$  voting on whether a given  $u$  should be classified as  $A$  or not  $A$ . Then,  $\Pr(A|u)$  may be interpreted as the probability that a voter picked at random would classify  $u$  as  $A$ . In this sense,  $\mu_{young}(25) = .8$  means that the probability that a voter picked at random would classify 25 as *young* is .8. Equivalently, .8 may be equated to the proportion of voters in  $V$  who classify 25 as *young*. It is this voting—or consensus—model that may be viewed as an interpretation of Loginov's suggestion.

Loginov's suggestion (or interpretation) has serious drawbacks. In the first place, it is unnatural to force a voter to choose either  $A$  or not  $A$  when  $A$  is a fuzzy concept in which the transition from membership to nonmembership is gradual rather than abrupt. More importantly, the consensus model does not make sense when subjective judgment is involved. For example, if the designer of a system states the rule "If pressure is high, then volume is low," how could the meaning of *high* and *low* be determined by consensus? How could the underlying probabilities "be determined subjectively or estimated by observation of human operators" (p. 000), as suggested in the article under discussion? How would one give a probabilistic answer to the question "In your perspective, what is the degree to which Mary is tall?" or "What is the degree to which Mary resembles Cindy?" What must be considered is that for humans it is generally much easier to estimate grades of membership or degrees of possibility rather than probabilities. This is one of the reasons why Loginov's interpretation—though known for a long time—has found little use in applications of fuzzy logic.

An interpretation of the membership function that is closely related to Loginov's involves the concept of a random set—that is, a set-valued random variable. More specifically, in the context of the voting model, assume that a voter  $V_i$  classifies  $u$  as  $A$  if  $u$  falls in an interval  $A_i$ . For example, 25 is classified as *young* if  $25 \in [0, 30]$ .

In this way, the collection of voters  $\{V_1, \dots, V_N\}$  induces a collection of intervals  $\{A_1, \dots, A_N\}$ . It follows that to say (a) that  $V_i$  classifies  $u$  as  $A$  is equivalent to saying that  $u \in A_i$  and (b) that picking a voter at random from  $\{V_1, \dots, V_N\}$  is equivalent to picking an interval at random from  $\{A_1, \dots, A_N\}$ .

Because the  $A_i$  may not be distinct, the uniform probability distribution on  $\{V_1, \dots, V_N\}$  induces, in general, a nonuniform probability distribution ( $p_1, \dots, p_K$ ) on the subset of distinct intervals, say  $\{A_1^*, \dots, A_K^*\}$ , of  $\{A_1, \dots, A_N\}$ . Then, the set-valued random variable

$\{(A_1^*, p_1), \dots, (A_K^*, p_K)\}$  may be viewed as a random set. In terms of this random set,  $\mu_A(u)$  may be interpreted as the probability of coverage of  $u$  by  $\{A_1^*, \dots, A_K^*\}$ . More specifically, if

$$a_j = \begin{cases} 1 & \text{if } u \in A_j^* \\ 0 & \text{if } u \notin A_j^* \end{cases}$$

then  $\mu_A(u) = a_1 p_1 + \dots + a_K p_K$ .

In a more general approach, which was developed in detail by Orlov (1980), Goodman and Nguyen (1985), Wang and Sanchez (1982), and others, the random set is generated by the  $\alpha$  cuts (or level sets) of  $A$ . More specifically, an  $\alpha$  cut,  $A_\alpha$ , of  $A$  is a nonfuzzy set defined by  $A_\alpha = \{u | \mu_A(u) \geq \alpha\}$ ,  $0 \leq \alpha \leq 1$ . The  $\alpha$  cuts are taken to be the constituents of a random set, with  $\alpha$  assumed to be uniformly distributed over the interval  $[0, 1]$ .

In this way, a fuzzy set  $A$  may be derived from a random set. In actuality, however, the same result can be achieved without bringing randomness into the picture. More specifically, it is well known that a fuzzy set can be generated from its  $\alpha$  cuts both disjunctively and additively. To show this, let  $\mu_{A_\alpha}(u)$  denote the membership function of  $A_\alpha$ —which, because  $A_\alpha$  is nonfuzzy, coincides with the characteristic function of  $A_\alpha$ . Then, the membership function of  $A$  may be expressed in terms of the membership functions of the  $A_\alpha$  (a) disjunctively as  $\mu_A(u) = \sup_\alpha (\alpha \wedge \mu_{A_\alpha}(u))$ ,  $0 \leq \alpha \leq 1$ , where  $\wedge$  denotes min, and (b) additively as

$$\mu_A(u) = \int_0^1 \mu_{A_\alpha}(u) d\alpha.$$

The additive representation is illustrated in Figures 1 and 2.

The random set representation of a fuzzy set is of substantial theoretical interest. It has not played a significant role in the applications of fuzzy logic largely because of the difficulty of dealing with random sets.

In another direction, the random set representation underlies the connection between the concept of possibility

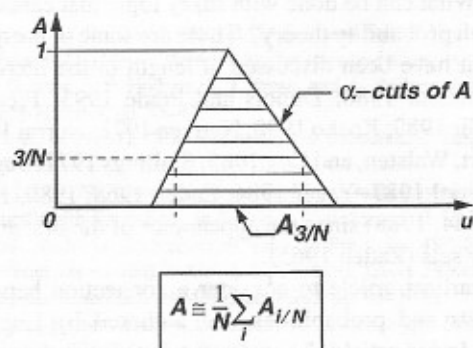

$A =$  arithmetic average of its  $\alpha$ -cuts

$A =$  expectation of a uniformly distributed random set

Figure 1. Additive Decomposition of a Fuzzy Set. The  $\alpha$  cuts are discretized.

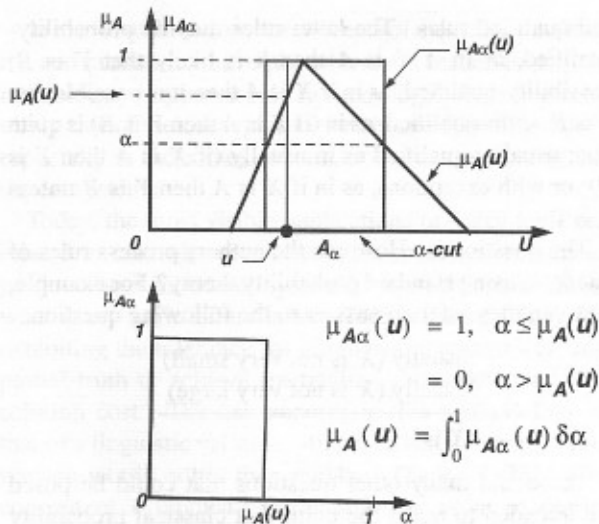

Figure 2. Additive Decomposition of a Fuzzy Set. The  $\alpha$  cuts form a continuum.

measure in fuzzy logic and the concept of plausibility measure in the Dempster-Shafer theory (Shafer 1976). Specifically, the two concepts coincide when the focal sets in the Dempster-Shafer theory are consonant—that is, nested. In this case, the focal sets may be regarded as the  $\alpha$  cuts of a fuzzy set, and the Dempster-Shafer structure may be viewed as a random set whose constituents are the focal sets. As in the case of the random set representation of a fuzzy set, however, randomness in the Dempster-Shafer theory may be replaced by an additive representation (Zadeh 1986).

In summary, it is possible, in a restricted way, to represent a fuzzy set as a random set or as a disjunctive or additive combination of nonfuzzy sets. This is illustrated in Figure 3. The important point to note is that the connection between fuzzy sets and random sets in no way implies that fuzziness and randomness are identical concepts or that fuzzy logic and probability theory have the same foundation and similar agendas.

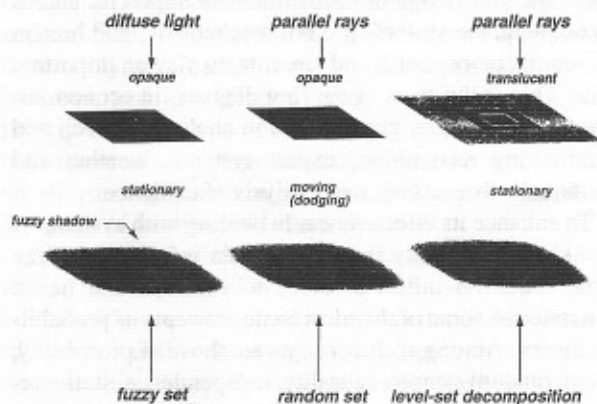

Figure 3. Optical Generation of a Fuzzy Set by a Random Set and Additive Decomposition.

## 2. LIMITATIONS OF PROBABILITY THEORY

In the article under discussion, it is suggested that (a) probability theory can do anything that can be done with fuzzy logic and (b) that there would be many more applications of probability theory in areas in which fuzzy logic has been used with success if probabilists and statisticians were more adept at "selling" their tools.

In reality, the applications of fuzzy logic are growing rapidly in number and variety largely because fuzzy logic fills a definite need for ways of dealing with problems in which the sources of imprecision and uncertainty do not lend themselves to analysis by conventional methods. In essence, what fuzzy logic offers—and what is clearly a useful offering—is a methodology for computing with words rather than numbers.

In this perspective, let us examine—as was done by Zadeh (1986)—the reasons why classical probability theory falls short of providing a comprehensive methodology for dealing with uncertainty and imprecision.

1. Probability theory does not support the concept of a fuzzy event. Simple examples of propositions involving fuzzy events are as follows: tomorrow will be a warm day; there will be a strong earthquake in the near future; the prices will stabilize in the long run.

The incapability of dealing with fuzzy events places a roadblock to applying probability theory to inference from fuzzy premises that represent real-world knowledge. In this connection, it is important to note that in the case of propagation of probabilities in belief networks a problem that arises is that the events associated with nodes are fuzzy rather than crisp. For example a node labeled *arthritis* may be linked to nodes labeled *swollen joints* and *painful joints*. It is a common practice to associate conditional numerical probabilities with such links. But the question is: What is the meaning of such probabilities? A related question is: How can the independence of fuzzy events be defined? These questions are not raised—much less answered—in the theory of Bayesian belief networks.

2. Probability theory offers no techniques for dealing with fuzzy quantifiers like *many*, *most*, *several*, *few*.

3. Probability theory does not provide a system for computing with fuzzy probabilities expressed as *likely*, *unlikely*, *not very likely*, and so forth. Such probabilities are not second-order probabilities.

4. Probability theory does not provide methods for estimating fuzzy probabilities. Subjective probability theory serves the purposes of elicitation rather than estimation. It provides no answers to questions exemplified by "What is the probability that my car may be stolen?" In this connection, it should be noted that, in most instances, subjective probabilities are rooted in fuzzy perceptions of frequency-based probabilities.

5. Probability theory is not sufficiently expressive as a meaning-representation language. For example, what is the meaning of "It is not likely that there will be a sharp increase in the price of oil in the near future"?

6. The limited expressive power of probability theory makes it difficult to analyze problems in which the data are described in fuzzy terms. Consider, for example, the following questions:

- An urn contains approximately 20 balls of various sizes of which several are large, a few are small, and the rest are of medium size. What is the probability that a ball drawn at random is neither large nor small?
- A variable  $X$  can take the values *small*, *medium*, and *large* with respective probabilities *low*, *high*, and *low*. What is the expected value of  $X$ ? What is the probability that  $X$  is *not large*?

Turning to the applications in control, in the article under discussion the authors consider a very simple example in which the rules are of the form if  $X$  is  $A$  then  $Y$  is  $B$ . In most practical applications, however, the rules are of the more general form if  $X_i$  is  $A_{ij}$  and  $\dots$  and  $X_n$  is  $A_{in}$ , then  $Y$  is  $B_i$ ,  $i = 1, 2, \dots, m$ . In this setting, the problem of interpolation is that of computing  $B$  in  $Y$  is  $B$  when  $X_1$  is  $A_1, \dots, X_n$  is  $A_n$ .

How would the authors solve this problem? How would they treat problems in which conjunction and disjunction are specified  $t$  norms and  $s$  norms rather than min and max?

In general, probability theory is not an appropriate tool to use in the solution of deterministic control problems. A case in point is the parallel-parking problem. How would the authors solve this problem? A more difficult dynamic motion-planning problem is the fuzzy ball-and-beam problem (Zadeh 1994a), which is illustrated in Figure 4. In this case, the problem is to transfer the ball from an initial position at the center to a point in a specified interval  $[a_1, a_2]$  on the beam at a time  $t$ , which is specified to be in an interval  $[t_1, t_2]$ . The beam is covered with a strip of fuzzy felt to complicate the formulation of equations of motion and thereby preclude the possibility of simulation.

Going beyond control, one of the principal tools in the tool chest of fuzzy logic is a language for manipulating a wide variety of both categorical (i.e., unqualified)

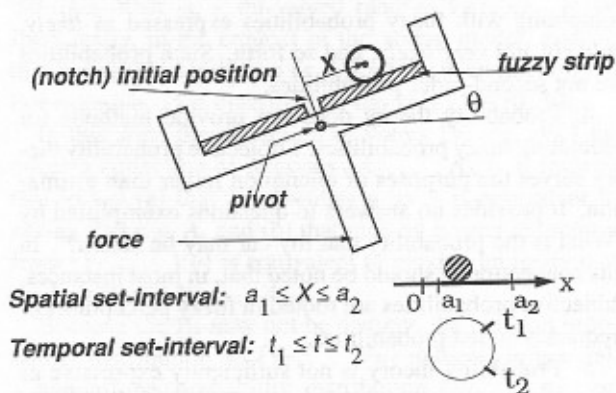

Figure 4. The Fuzzy Ball-and-Beam Problem. The ball rolls/slides on a fuzzy strip, which is attached to a beam.

and qualified rules. The latter rules may be probability-qualified, as in if  $X$  is  $A$  then it is likely that  $Y$  is  $B$ ; possibility-qualified, as in if  $X$  is  $A$  then it is possible that  $Y$  is  $B$ ; truth-qualified, as in (if  $X$  is  $A$  then  $Y$  is  $B$ ) is quite true; usuality-qualified as in usually (if  $X$  is  $A$  then  $Y$  is  $B$ ); or with exceptions, as in if  $X$  is  $A$  then  $Y$  is  $B$  unless  $Z$  is  $C$ .

The question is: How can the authors process rules of this form using standard probability theory? For example, how can they infer an answer to the following question:

usually ( $X$  is not very small)  
usually ( $X$  is not very large)  

---

 $X$  is?

These and many other questions that could be posed are intended to make the point that classical probability theory has definite limitations—limitations that stem for the most part from an avoidance of issues and problems in which fuzziness lies at the center rather than on the periphery. What has to be recognized is that in real-world settings such issues and problems are the rule rather than the exception.

### 3. COMPLEMENTARITY OF PROBABILITY THEORY AND FUZZY LOGIC

In the article under discussion, the authors take the position that fuzzy logic does not have much to add to what can be done through the use of standard probability-based techniques. The thrust of our arguments is that this is not the case.

Clearly, classical probability theory has been and continues to be employed with remarkable success in those fields in which the systems are mechanistic, and human reasoning, perceptions, and emotions do not play a significant role. Such is the case in statistical mechanics, theories of turbulence, quantum mechanics, communication systems, evolutionary programming, and related fields.

What should be recognized, however, is that classical probability theory is much less effective in those fields in which the dependencies between variables are not well defined, the knowledge of probabilities is imprecise and/or incomplete, the systems are not mechanistic, and human reasoning, perceptions, and emotion do play an important role. This is the case, in varying degrees, in economics, pattern recognition, group decision analysis, speech and handwriting recognition, expert systems, weather and earthquake forecasting, and analysis of evidence.

To enhance its effectiveness in dealing with systems of this kind, probability theory needs an infusion of fuzzy logic. Such an infusion serves to fuzzify—and hence generalize—some of the most basic concepts of probability theory. Among such concepts are those of probability, event, random sample, causality, independence, stationarity, similarity, and convergence. This is the sense in which the complementarity of probability theory and fuzzy logic should be understood.

In a reverse direction, the concepts of measure, cardinality, and probability have played and are certain to play an increasingly important role in fuzzy logic. This is particularly true of the concepts of usuality and dispositionality, especially in the context of common-sense reasoning and expert systems.

Today, the most visible applications of fuzzy logic are related to control, especially in the realms of consumer products and industrial systems. In such applications, what fuzzy logic offers is an effective methodology for exploiting the tolerance for imprecision, uncertainty, and partial truth to achieve tractability, robustness, and low solution cost. The key concept in this methodology is that of a linguistic variable—that is, a variable whose values are words rather than numbers (Zadeh 1973). The concept of a linguistic variable is the point of departure for the development of the calculus of fuzzy if-then rules.

In coming years, the concept of a linguistic variable and the calculus of fuzzy if-then rules are likely to play key roles in the symbiosis of probability theory and fuzzy logic. The development of a symbiotic relationship between probability theory and fuzzy logic should be an important objective for all of us.

#### 4. CONCLUDING REMARKS

I should like to compliment the authors of the article under discussion for arguing with conviction and cogency their case for the sufficiency of standard probability theory and statistical methods.

What has to be recognized, however, is that in science as in other domains of human activity there is a tendency to be nationalistic—to embrace a particular methodology and take a skeptical view of the other methodologies that are asking for a place at the table.

In many cases there is more to be gained from cooperation than from arguments over which methodology is best. A case in point is the concept of *soft computing* (Zadeh 1994b). Soft computing is not a methodology—it is a partnership of methodologies that function effectively in an environment of imprecision and/or uncertainty and are aimed at exploiting the tolerance for imprecision, uncertainty, and partial truth to achieve tractability, robustness, and low solution costs. At this juncture, the principal constituents of soft computing are fuzzy logic, neurocomputing, and probabilistic reasoning, with the latter subsuming genetic algorithms, evidential reasoning, and parts of learning and chaos theories.

Although the article under discussion argues in favor of sufficiency of probability theory, it is in fact a significant contribution to the development of a better understanding of how probability theory and fuzzy logic can act in concert. In this sense, it is consistent with the aims of soft computing.

A final note—a minor matter of semantics: In the article under discussion, the authors employ interchangeably the

terms *fuzzy* and *vague*. In fact, fuzzy and vague are distinct concepts, as was pointed out by Zadeh (1979). More specifically, a proposition is fuzzy if it contains terms that are labels of fuzzy sets. For example, "I will be back in a few minutes" is a fuzzy proposition by virtue of the fuzziness of *few*.

A proposition is vague if it is insufficiently specific for a specified purpose. For example, "I will be back sometime" is vague if it is insufficiently specific. An example of a common vague proposition is "Use with adequate ventilation." Vagueness is a property of propositions rather than predicates and, in most cases, is purpose dependent. Note that a proposition may be vague without being fuzzy. Usually a vague proposition is fuzzy, but the converse is not generally true.

#### ACKNOWLEDGMENTS

Research was supported in part by NASA Grant NCC 2-275, EPRI Agreement RP 8010-34, and the BISC (Berkeley Initiative in Soft Computing) Program.

#### ADDITIONAL REFERENCES

- Buonocristiani, J. (1980), *Probability on Fuzzy Sets*, unpublished Ph.D. thesis, Boston University, Dept. of Mathematics.
- Freeling, A. N. S. (1981), *Possibilities Versus Fuzzy Probabilities—Two Alternative Decision Aids*, Tech. Report 81-6, Decision Science Consortium Inc., Washington, DC.
- Goodman, I. R., and Nguyen, H. T. (1985), *Uncertain Models for Knowledge-Based Systems*, Amsterdam: North-Holland.
- Klir, G. J. (1989), "Is There More to Uncertainty Than Some Probability Theorists Might Have Us Believe?" *International Journal of General Systems*, 15, 347-378.
- Logunov, V. J. (1966), "Probability Treatment of Zadeh Membership Functions and Their Use in Pattern Recognition," *Engineering Cybernetics*, 68-69.
- Nguyen, H. T. (1977), "On Fuzziness and Linguistic Probabilities," *Journal of Mathematical Analysis and Applications*, 61, 658-671.
- Nurmi, H. (1977), "Probability and Fuzziness: Some Methodological Considerations," unpublished paper presented at the *Sixth Research Conference on Subjective Probability, Utility, and Decision Making*, Warszawa.
- Orlov, A. I. (1980), *Problems of Optimization and Fuzzy Variables*, Moscow: Znaniye.
- Rapoport, A., Wallsten, T., and Cox, J. (1985), "Direct and Indirect Scaling of Membership Function of Probability Phrases," Tech. Report 174, University of North Carolina, Psychometric Laboratory.
- Shafer, G. (1976), *A Mathematical Theory of Evidence*, Princeton, NJ: Princeton University Press.
- Stallings, W. (1977), "Fuzzy Set Theory Versus Bayesian Statistics," *IEEE Transactions on Systems, Man, and Cybernetics*, SMC-7, 216-219.
- Sugeno, M. (1977), "Fuzzy Measures and Fuzzy Integrals: A Survey," in *Fuzzy Automata and Decision Processes*, eds. M. M. Gupta, G. N. Saridis, and B. R. Gaines, Amsterdam: North-Holland, pp. 89-102.
- Viertl, R. (1987), "Is It Necessary to Develop a Fuzzy Bayesian Inference?" in *Probability and Bayesian Statistics*, ed. R. Viertl, New York: Plenum, pp. 471-475.
- Wang, P. Z., and Sanchez, E. (1982), "Treating a Fuzzy Subset as a Projectable Random Set," in *Fuzzy Information and Decision Processes*, eds. M. M. Gupta and E. Sanchez, Amsterdam: North-Holland, pp. 213-220.

- Yager, R. R. (1984), "Probabilities From Fuzzy Observations," *Information Sciences*, 32, 1-31.
- Zadeh, L. A. (1968), "Probability Measures of Fuzzy Events," *Journal of Mathematical Analysis and Applications*, 23, 421-427.
- (1973), "Outline of a New Approach to the Analysis of Complex System and Decision Processes," *IEEE Transactions on Systems, Man, and Cybernetics*, SMC-3, 28-44.
- (1979), "PRUF—A Meaning Representation Language for Natural Languages," *International Journal of Man-Machines Studies*, 10, 395-460.
- (1980), "Fuzzy Sets vs. Probability" (correspondence item), *Proceedings of the IEEE*, 68, 421.
- (1981), "Fuzzy Probabilities and Their Role in Decision Analysis," *Proceedings of the MIT/ONR Workshop on C<sup>3</sup>*, Cambridge, MA: MIT.
- (1983), "Is Possibility Different From Probability?" *Human Systems Management*, 3, 253-254.
- (1984), "Fuzzy Probabilities," *Information Processing and Management*, 19, 148-153.
- (1986), "A Simple View of the Dempster-Shafer Theory of Evidence and Its Implications for the Rule of Combination of Evidence," *AI Magazine*, 7, 85-90.
- (1988), "On the Treatment of Uncertainty in AI," *The Knowledge Engineering Review*, 2, Pt. I, 81-85.
- (1994a), "Soft Computing and Fuzzy Logic," *IEEE Software*, 11, 48-56.
- (1994b), "Fuzzy Logic, Neural Networks and Soft Computing," *Communications of the ACM*, 37, 77-84.
- Zwick, R. (1985), "Fuzzy Probabilities," unpublished paper presented at the 18th Annual Mathematical Psychology Meeting, La Jolla, CA.

© 1995 American Statistical Association and  
the American Society for Quality Control

# Discussion: On the Very Real Distinction Between Fuzzy and Statistical Methods

**Abraham KANDEL**

Department of Computer Science and  
Engineering  
University of South Florida  
Tampa, FL 33620

**Alejandro MARTINS**

Department of Production  
Engineering  
Federal University of Santa Catarina  
Florianópolis, Brazil

**Roberto PACHECO**

Department of Industrial and  
Management Systems  
University of South Florida  
Tampa, FL 33620

In this discussion we review the main remarks of Laviolette, Seaman, Barrett, and Woodall. First, we examine how the subjectivist view of probability faces the task of modeling human reasoning according to a cognitive viewpoint. We then investigate the nature of the fuzzy and probabilistic controllers analyzed by the authors, refuting the hypothesis of similarity. We show that, due to the different theoretical basis, the representativeness of the fuzzy controller overcomes the probabilistic controller in resembling the expert's knowledge. We also review the authors' comparison between the fuzzy and probabilistic approaches to monitor multinomial processes, emphasizing biases and misconceptions in the authors' analysis.

**KEY WORDS:** Fuzzy control; Fuzzy set theory; Probability theory; Statistical control.

## 1. INTRODUCTION

Once again, researchers of fuzzy set theory (FST) are invited to discuss the differences between probabilistic and fuzzy models, continuing the endless debate of probability versus fuzziness. In fact, Laviolette, Seaman, Barrett, and Woodall (from now on LSBW) have created another excellent opportunity to emphasize the distinctions between these theories regarding their foundations and applications.

LSBW's article posits that probabilistic models can perform as well as fuzzy models in industrial applications. The authors conclude that probabilistic models deal with the same entities purportedly employing a stronger justification with closer resemblance to human thought. The authors also present two examples of fuzzy applications and build alternative statistical approaches. They suggest the superiority of the latter based upon the aforementioned reasons and on a simpler computational implementation.